



EX200

- I** Smerigliatrice da banco
GB Bench grinder
F Touret à meuler
E Esmeriladora de banco
GR Τριβείο πάγκου

DATI TECNICI

1. Tensione di alimentazione e frequenza nominale
2. Potenza nominale
3. Numero giri a vuoto
4. Diametro massimo mola a disco
5. Tipo servizio di funzionamento non continuo
6. Livello di pressione acustica

MOLA ABRASIVA

7. Dimensioni (ø est. x spessore x ø int.)
8. Forma (sec. EN12413)
9. Sigla materiale

TECHNICAL DATA

1. Power supply voltage and rated frequency
2. Rated power
3. Number of revolutions at idle
4. Maximum diameter of disc grinding wheel
5. Non continuous functioning service type
6. Acoustic pressure

ABRASIVE GRINDING WHEEL

7. Dimensions (ext. ø x thickness x int. ø)
8. Shape (sec. EN12413)
9. Material initials

1	230 V~50 Hz
2	350 W
3	2950 min ⁻¹
4	ø200 mm
5	S2 30 min
6	LpA 79 dB(A)

7	ø200x20xø16 mm
8	Tipo 1 - mola piana
9	A36 - A60

DONNÉES TECHNIQUES

1. Tension d'alimentation et fréquence nominale
2. Puissance nominale
3. Nombre de tours à vide
4. Diamètre maximum meule
5. Type de service intermittent
6. Pression acoustique

MEULE SÈCHE

7. Dimensions (ø ext. x épaisseur x alésage)
8. Forme (selon EN12413)
9. Sigla matériau

DATOS TÉCNICOS

1. Tensión de alimentación y frecuencia nominal
2. Potencia nominal
3. Número de revoluciones en vacío
4. Diámetro máximo muela de disco
5. Tipo de servicio intermitente
6. Presión acústica

MUELA ABRASIVA

7. Medidas (ø ext. x espesor x ø int.)
8. Forma (según EN12413)
9. Sigla material

ΤΕΧΝΙΚΑ ΣΤΟΙΧΕΙΑ

1. Τάση τροφοδοσίας και ονομαστική συχνότητα
2. Ονομαστική ισχύς
3. Αριθμός στροφών χωρίς φορτίο
4. Μέγιστη διάμετρος δίσκου
5. Τύπος χρήσης μη συνεχούς λειτουργίας
6. Ηχητική πίεση

ΔΙΣΚΟΣ ΛΕΙΑΝΣΗΣ

7. Διαστάσεις (ψ εξωτ. x πάχος ψ εσωτ.)
8. Σχήμα (σύμφ. EN12413)
9. Αρτικώλεξο υλικού

DICHIARAZIONE DI CONFORMITÀ

La ditta indicata in etichetta dichiara sotto la propria responsabilità che il prodotto ivi citato è conforme ai requisiti essenziali di sicurezza e salute contenuti nelle seguenti direttive europee:
2006/42/CE, 2004/108/CE

DECLARATION OF CONFORMITY

The firm indicated on the label declares, under its own responsibility, that the product cited there complies with the essential health and safety requirements contained in the following European directives:
2006/42/EC, 2004/108/CE

DÉCLARATION DE CONFORMITÉ

La Société indiquée sur l'étiquette déclare sous sa responsabilité que le produit concerné est conforme aux exigences essentielles de sécurité et santé prescrites par les directives européennes suivantes:
2006/42/CE, 2004/108/CE

DECLARACIÓN DE CONFORMIDAD

La empresa indicada en la etiqueta declara bajo su propia responsabilidad que el producto mencionado se encuentra conforme a los requisitos esenciales de seguridad y salud establecidos por las siguientes directivas europeas:
2006/42/CE, 2004/108/CE

ΔΗΛΩΣΗ ΣΥΜΜΟΡΦΩΣΗΣ

Η εταιρία που αναφέρεται στην ετικέτα δηλώνει υπεύθυνα ότι το προϊόν που αναφέρεται εδώ είναι σύμφωνο με τις βασικές προδιαγραφές ασφαλείας και υγείας που περιέχονται στις ακόλουθες ευρωπαϊκές οδηγίες:
2006/42/ΕΚ, 2004/108/ΕΚ

Persona autorizzata a costituire il fascicolo tecnico presso/ The person authorized to compile the technical file is in

Valex SpA - Via Lago Maggiore 24 - 36015 Schio (VI) - Italy

Schio, 04.2012

Un procuratore - Attorney - Un fondé de pouvoir - Un procurador - Ο πληρεξούσιος

ARRIGO ZANELLA

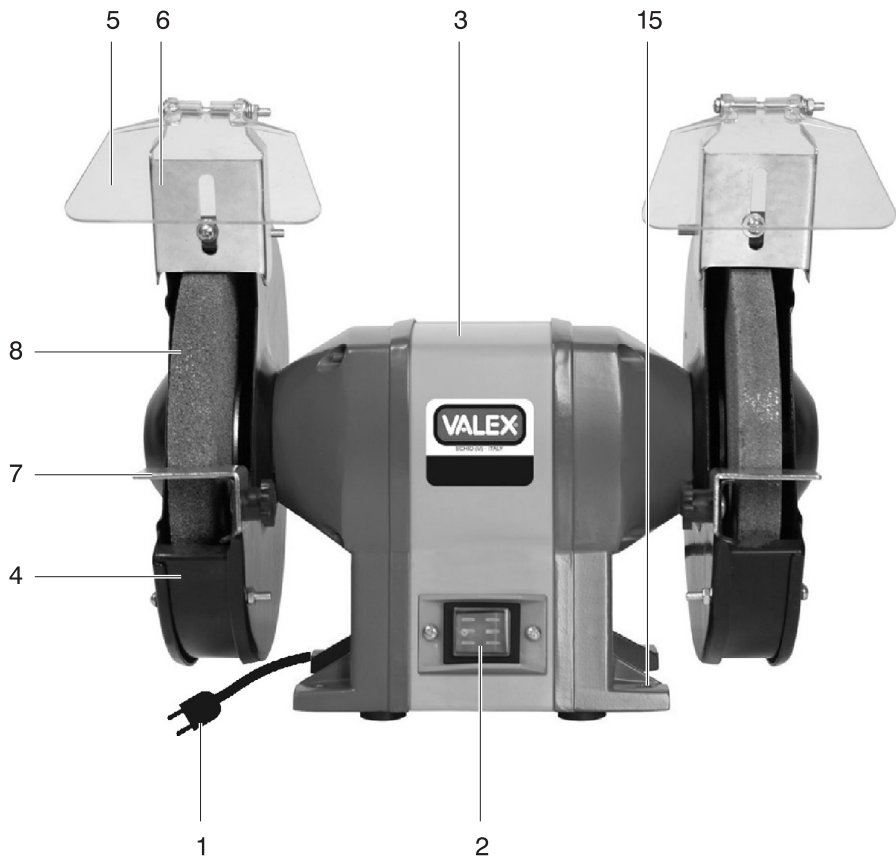
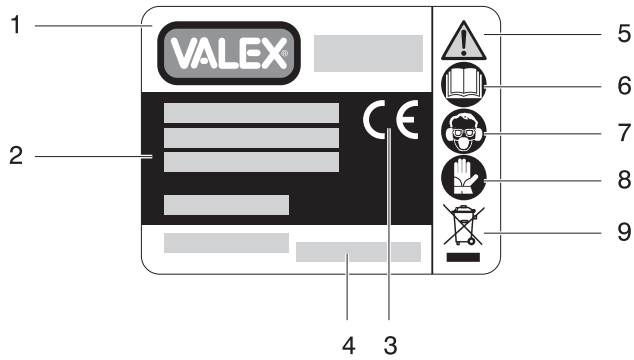
A**B**

C

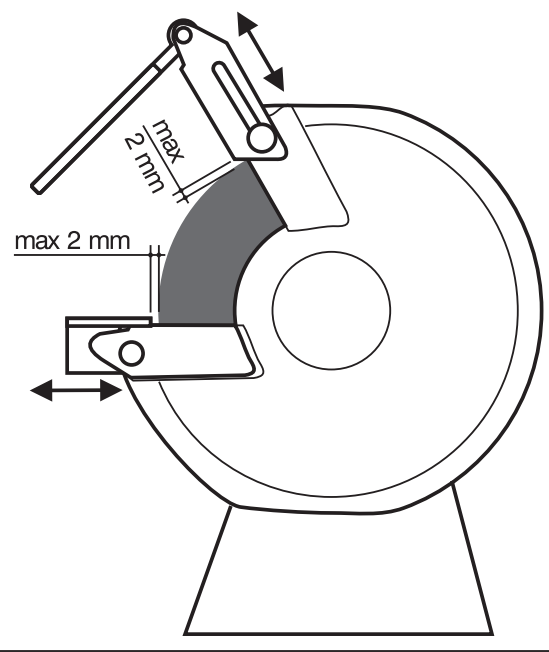

F



G



NO!

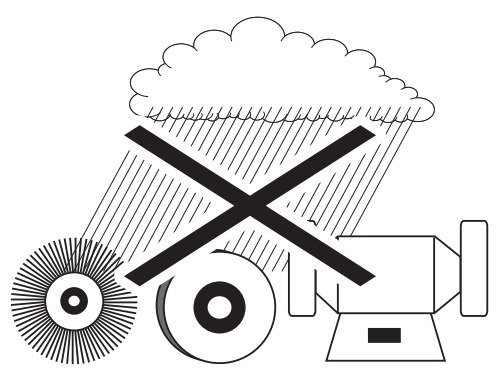

Haccesso
ON

max 30 min

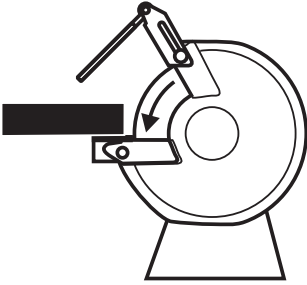
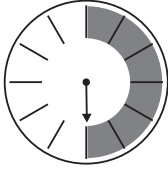
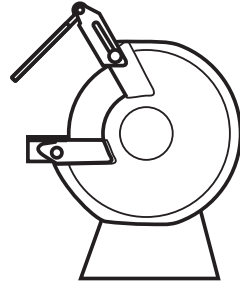
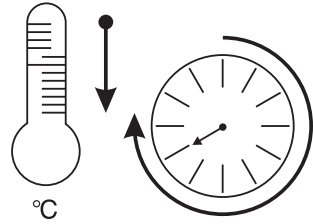
spento
OFF**L**