



AC PUMPS PANTHER 56 - 72

IT. Elettropompe per travaso gasolio. Rotative, volumetriche autoadescenti a palette. Dotate di valvola by-pass. Tenuta di elevata affidabilità anche con basse temperature di utilizzo. Compatte e facili da installare sono ideali per distributori ed impianti fissi di travaso carburante e altre applicazioni industriali. Robusta struttura in ghisa, pompa a palette con rotore in acciaio sinterizzato e palette in resina acetaleica, motore a induzione con carcassa in alluminio. Utilizzabile in continuo con protezione termica per sovraccarico motore.

FR. Electropompes pour transvasement du gasoil. Rotatives, volumétriques à amorçage automatique à ailettes. Pourvues de vanne by-pass. Etanchéité hautement fiable même en utilisation à basse température. Compactes et faciles à installer, elles conviennent très bien pour distribuer en installation fixe de transvasement de carburant et autres applications industrielles. Structure robuste en fonte, pompe à ailettes avec rotor en acier fritté et ailettes en résine acétale, moteur d'induction avec corps en aluminium. Utilisable en continu avec protection thermique en cas de surcharge du moteur.

DE. Elektropumpen zur Dieselförderung. Selbstansaugende Flügelzellenverdrängerpumpen. Ausgestattet mit integriertem ByPass Ventil. Sehr zuverlässige Dichtung auch bei niedrigen Gebrauchstemperaturen. Sie sind kompakt und leicht anzubringen, ideal für Zapfstellen und ortsfeste Kraftstoff-Förderanlagen sowie andere industrielle Anwendungen. Widerstandsfähige Struktur aus Gusseisen, Flügelzellenpumpe mit Rotor aus Sinterstahl und Flügeln aus Acetalharz, Induktionsmotor mit Aluminiumgehäuse. Für Dauerbetrieb mit thermischer Schutzabschaltung.

PERFORMANCE

- Portata fino a 72 l/min
- Funzionamento continuo AC
- Rumorosità minore di 75 dB
- Filtro incorporato
- Débit : jusqu'à 72 l/min
- Fonctionnement continu CA
- Bruit : inférieur à 75 dB
- Filtre incorporé
- Durchflussmenge bis 72 l/Min.
- Dauerbetrieb AC
- Kleinster Lärmpegel 75 dB
- Eingebauter Filter

DIMENSIONS

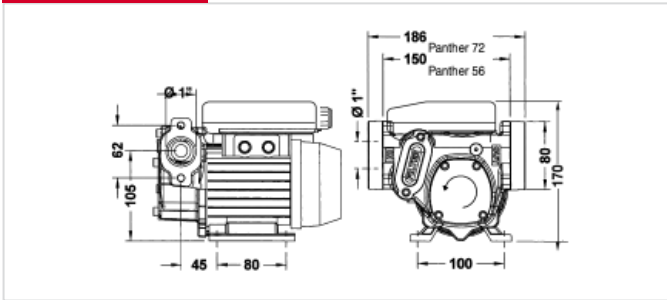

PRODUCTS' RANGE WEIGHT AND PACKAGING

Code	Weight		Packaging		
	kg	lbs	mm	inch	pcs/box
PANTHER 56					
F00730000	7,4	16,3	345X175X255	13,6x6,9x10	1
000731000	7,4	16,3	345X175X255	13,6x6,9x10	1
000730070	7,4	16,3	345X175X255	13,6x6,9x10	1
F00730380	7,4	16,3	345X175X255	13,6x6,9x10	1
000733000	7,4	16,3	345X175X255	13,6x6,9x10	1
000734000	7,4	16,3	345X175X255	13,6x6,9x10	1
PANTHER 72					
000732000	7,9	17,4	345X175X255	13,6x6,9x10	1
000735000	7,9	17,4	345X175X255	13,6x6,9x10	1



PANTHER 72

PANTHER 56

Flow-rate

up to
72 l/min
(up to 19 gpm)

PIUSI



PANTHER 56
THREADED PORTS
(flange not included)



PANTHER 72
(threaded flange included)

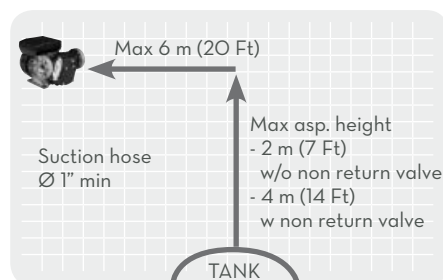
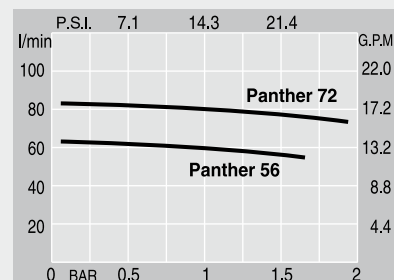

FEATURES

Vane rotors

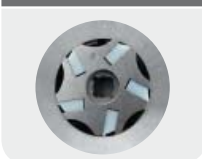

Filter



ON REQUEST

Flange connect.



PRODUCTS' RANGE TECHNICAL DATA

Code	Description	Fluids type	Flow-rate		Voltage				rpm	Inlet Outlet BSP	Flange connection	Bypass valve	Inlet filter
			l/min	gpm	Singlephase motor V/Hz	Threephase motor V/Hz	Power Watt	Amp. max.					
PANTHER 56													
F00730000	Panther 56 230/50	D	56	15	230/50	-	600	3	2900	1"	-	YES	YES
000731000	Panther 56 230/60	D	68	18	230/60	-	800	3,9	3400	1"	-	YES	YES
000730070	Panther 56 120/60	D	56	15	120/60	-	800	7,5	3400	1"	-	YES	YES
F00730380	Panther 56 110/50	D	56	15	120/50	-	600	5,5	2800	1"	-	YES	YES
000733000	Panther 56 400/50	D	56	15	-	400/50	500	1,3	2900	1"	-	YES	YES
000734000	Panther 56 400/60	D	68	18	-	400/60	500	1,4	3400	1"	-	YES	YES
PANTHER 72													
000732000	Panther 72 230/50	D	72	19	230/50	-	850	4,2	2900	1"	YES	YES	YES
000735000	Panther 72 400/50	D	72	19	-	400/50	550	1,6	2900	1"	YES	YES	YES

Upon request it is available with different voltage and frequency