

Doppio cilindro con rinforzo e taglio
 Double cylinder with reinforce and cut

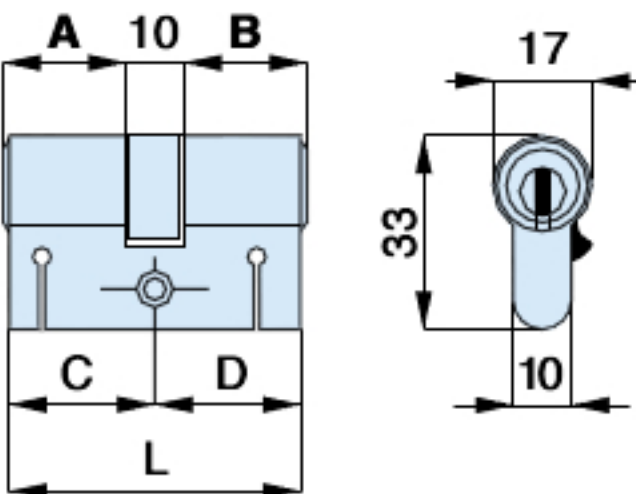

HSP



15	A	B	C	D	L	codice code	euro	
15	27	10	27	31	31	62	P33640 N00	1
15	27	10	31	31	35	66	P33680 N00	1
15	31	10	31	35	35	70	P33720 N00	1
15	27	10	37	31	41	72	P33740 N00	1
15	27	10	41	31	45	76	P33781 N00	1
15	31	10	37	35	41	76	P33782 N00	1
15	31	10	41	35	45	80	P33820 N00	1
15	27	10	47	31	51	82	P33841 N00	1
15	37	10	37	41	41	82	P33842 N00	1
15	27	10	51	31	55	86	P33881 N00	1
15	31	10	47	35	51	86	P33882 N00	1
15	37	10	41	41	45	86	P33883 N00	1
15	31	10	51	35	55	90	P33921 N00	1
15	41	10	41	45	45	90	P33922 N00	1
15	27	10	57	31	61	92	P33941 N00	1
15	37	10	47	41	51	92	P33942 N00	1
15	37	10	51	41	55	96	P33981 N00	1
15	41	10	47	45	51	96	P33982 N00	1
15	31	10	57	35	61	96	P33983 N00	1
15	41	10	51	45	55	100	P33020 N00	1
15	27	10	67	31	71	102	P33041 N00	1
15	37	10	57	41	61	102	P33042 N00	1
15	47	10	47	51	51	102	P33043 N00	1
15	27	10	77	31	81	112	P33141 N00	1
15	37	10	67	41	71	112	P33142 N00	1
15	47	10	57	51	61	112	P33143 N00	1
15	47	10	67	51	71	122	P33243 N00	1

con 5 chiavi with 5 keys

..... N50

frizionato frictioned

..... NOX