

Scrocco regolabile con mandate - Adjustable latch bolt with throws

Scrocco intercambiabile con rullo cod. 0395 - Latch bolt interchangeable into roller bolt cod. 0395

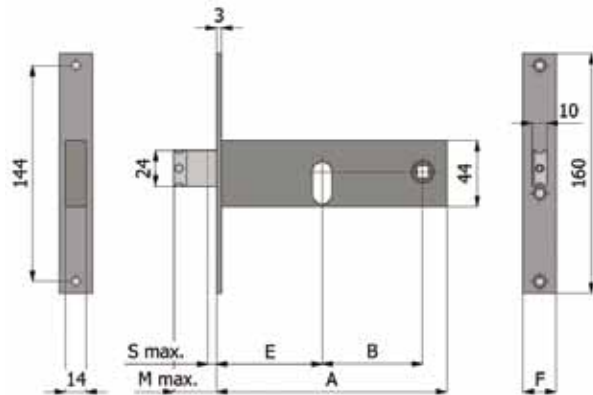

NEW

CARATTERISTICHE COSTRUTTIVE: Scatola e coperchio in acciaio zincato e plastificato - Frontale in acciaio nichelato e cromato - Scrocco in lega speciale nichelata - Ingegno maniglia in lega speciale zincata foro \square mm.8.

FUNZIONAMENTO: Mandate comandate dalla chiave - Scrocco comandato dalla chiave o dalla maniglia.

MANO: Reversibile.



PARTI IN DOTAZIONE: Vite cilindro.

CONSTRUCTIVE FEATURES: Zinc and plastic plated steel case and cover - Nickel and chromium plated steel forend - Special nickel-plated alloy latch bolt - Special zinc-plated alloy square spindle device \square mm.8.

WORKING: Key driven throws - Handle or key driven latch bolt.

HAND: Reversible.

PROVIDED WITH: Cylinder screw.

COD.	E	F	A	B	M max.	S max.	mandate throws				
390	60	16	133	47	33	6	2	0,36	1	10	
390/F22	60	22	133	47	33	6	2	0,38	1	10	
790	70	16	153	67	33	6	2	0,39	1	10	
790/F22	70	22	153	67	33	6	2	0,41	1	10	
790-TT/F15	70	14,6	153	67	33	6	2	0,39	1	10	
890	80	16	163	67	33	6	2	0,40	1	10	
890/F22	80	22	163	67	33	6	2	0,42	1	10	
890-TT/F15	80	14,6	163	67	33	6	2	0,40	1	10	
990	90	16	173	67	33	6	2	0,42	1	-	
990/F22	90	22	173	67	33	6	2	0,44	1	-	
990-TT/F15	90	14,6	173	67	33	6	2	0,42	1	-	